

# PRINCIPLE THREE:

## Simple and Intuitive Use

---

---

**Use of the design  
is easy to  
understand,  
regardless of the  
user's experience,  
knowledge,  
language skills,  
or current  
concentration  
level.**

principle three

**SIMPLE AND INTUITIVE USE**



3a1

Operation of single-lever faucet is readily understood without instruction or previous experience.

**GUIDELINE 3A:**

**Eliminate unnecessary complexity.**



3a2

Use of icons reduces complexity of control panel for hospital patient's room.

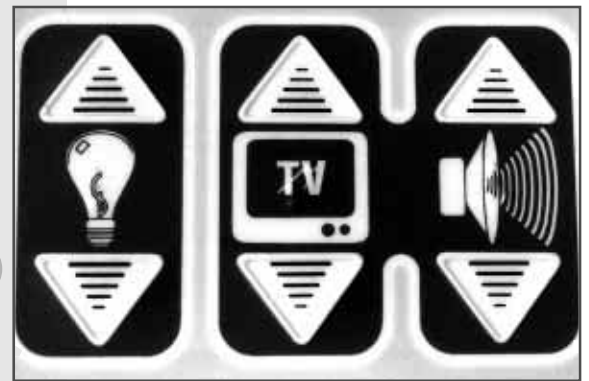

3a2 inset.

principle three

**SIMPLE AND INTUITIVE USE**

**GUIDELINE 3B:**

**Be consistent with user expectations and intuition.**

Generations of customers know what to expect inside this familiar, distinctive package.



3b1

Automobile power seat control switch mimics the shape of the seat, enabling driver or passenger to make adjustments intuitively.



3b2

principle three

**SIMPLE AND INTUITIVE USE**



3c1

Icons used in TV remote control design minimize the need for reading.



3c2

Icon labels adjacent to computer display controls describe each adjustment.

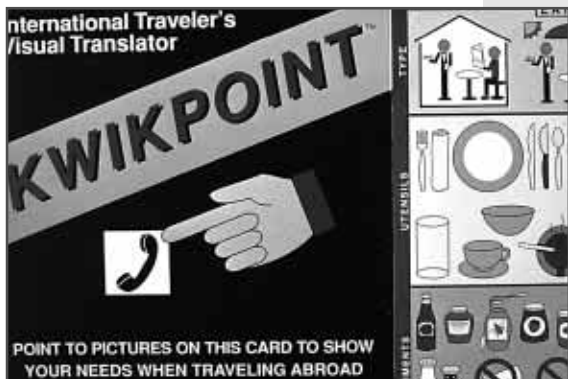

3c3

Pocket translation card for international travelers allows user to point to icons for communication.

Assembly instructions for imported furniture eliminate translation problems by providing clear illustrations without text.

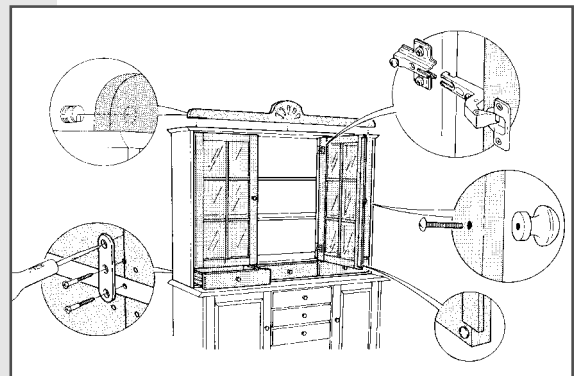

3c4

**GUIDELINE 3C:**

**Accommodate a wide range of literacy and language skills.**

principle three

**SIMPLE AND INTUITIVE USE**

**GUIDELINE 3D:**

**Arrange information consistent with its importance.**

Large memory-dial buttons in prominent location at top of phone pad speed emergency calls.



3d1

Illustrated and color coded warning label emphasizes precautions in taking cough medicine.

 **DOSAGE:** Follow dosage below or use as directed by a doctor. Dosage cup provided. Do not exceed doses in a 24-hour period.

 **ADULT DOSE (and children 12 yrs and over):**  
2 teaspoonfuls every 4 hrs.

 **CHILD DOSE**  
**6 yrs to under 12 yrs:**  
1 teaspoonful every 4 hrs.  
**2 yrs to under 6 yrs:**  
½ teaspoonful every 4 hrs.  
**under 2 yrs:** Consult your doctor.

3d2

The essential washing instructions are printed on the inside of clothes washer lid.

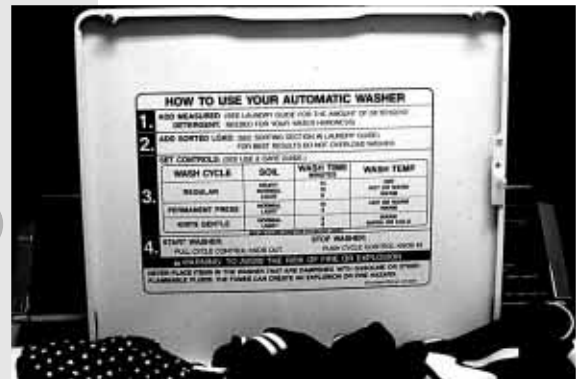

3d3

principle three

**SIMPLE AND INTUITIVE USE**

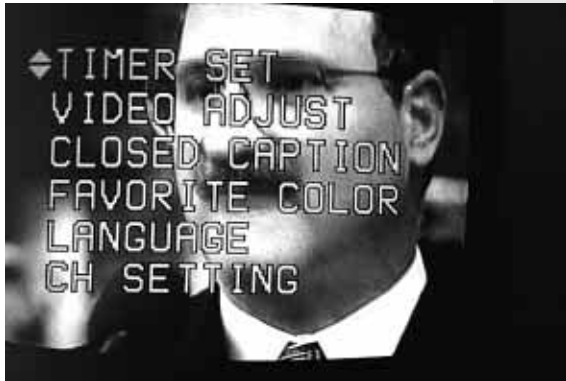

3e1

On-screen VCR programming takes the user through a step-by-step menu for setup and operations.

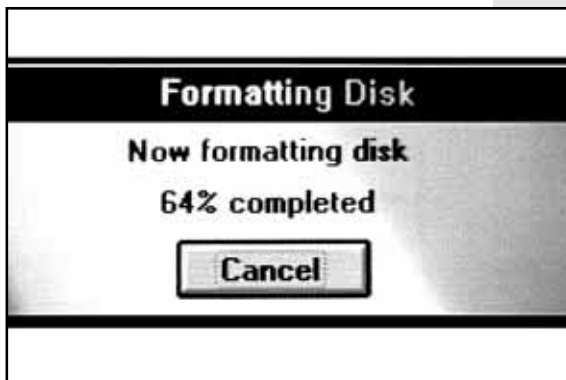

3e2

Computer screen shows portion of task completed to inform user of progress in disk formatting.



Numbered, step-by-step instruction manual guides user through the cooking process.



**GUIDELINE 3E:**

**Provide effective prompting and feedback during and after task completion.**



3e3

**principle three**

**SIMPLE AND INTUITIVE USE**

*Photography Credits*

---

---

- 3a1. The Center for Universal Design, Raleigh, North Carolina
- 3a2. The Center for Universal Design, Raleigh, North Carolina
- 3a2 inset. The Center for Universal Design, Raleigh, North Carolina

- 3b1. J.L. Mueller, Inc., Chantilly, Virginia
- 3b2. J.L. Mueller, Inc., Chantilly, Virginia

- 3c1. J.L. Mueller, Inc., Chantilly, Virginia
- 3c2. J.L. Mueller, Inc., Chantilly, Virginia
- 3c3. J.L. Mueller, Inc., Chantilly, Virginia
- 3c4. IKEA Svenska AB, Almhut, Sweden

- 3d1. The Center for Universal Design, Raleigh, North Carolina
- 3d2. J.L. Mueller, Inc., Chantilly, Virginia
- 3d3. J.L. Mueller, Inc., Chantilly, Virginia

- 3e1. J.L. Mueller, Inc., Chantilly, Virginia
- 3e2. J.L. Mueller, Inc., Chantilly, Virginia
- 3e3. The Center for Universal Design, Raleigh, North Carolina

